



BURGESS-MANNING

Burgess-Manning, Inc., Subsidiary of Nitram Energy, Inc.
227 Thorn Avenue, Orchard Park, NY 14127
Phone: (716) 662-6540 Fax: (716) 662-6548 Website: www.burgess-manning.com

MODEL BMER - Engine Exhaust Silencer

Burgess-Manning, Pioneer of Industrial Silencing announces A new line of Reciprocating Engine Exhaust Silencers

Description:

Burgess-Manning chambered reactive type engine silencers are specifically designed to provide ideal noise reduction of reciprocating engine exhaust gas and are available in six different grades. Burgess-Manning offers the industrial grade model BMEI (15-20 dB), residential grade model BMER (20-25 dB), critical grade model BMEC (25-30), critical plus grade model BMA (30-35 dB) hospital grade model BEO (35-40 dB), and hospital plus grade model BEOA (40+ dB).

Features:

- Noise reduction up to 25 dB
- Economically priced
- Long service life
- All welded steel construction for explosion resistant service

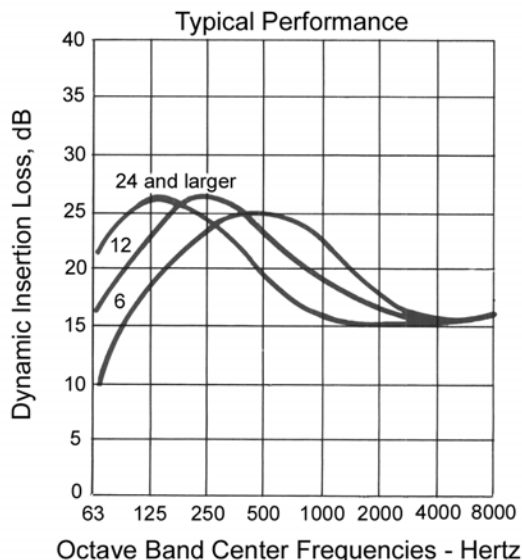

Specifications:

Maximum Noise Attenuation:	25 dB
Typical Sizes:	1" - 24"
Standard End Connections:	NPT or 125# ANSI Flanged
Standard Material of Construction:	Carbon Steel
Finish:	Prime Coated Exterior

Figure 1.0

Typical Burgess-Manning reactive type silencer



Theory of Operation:

The Burgess-Manning patented principle used in the design of Burgess-Manning silencers involves passing gas flow through snubbing chambers. These snubbing chambers house an arrangement of ported tubes, which attenuate the noise to smooth, quiet flow.



BURGESS-MANNING

Burgess-Manning, Inc., Subsidiary of Nitram Energy, Inc.

227 Thorn Avenue, Orchard Park, NY 14127

Phone: (716) 662-6540 Fax: (716) 662-6548 Website: www.burgess-manning.com

MODEL BMER - Engine Exhaust Silencer

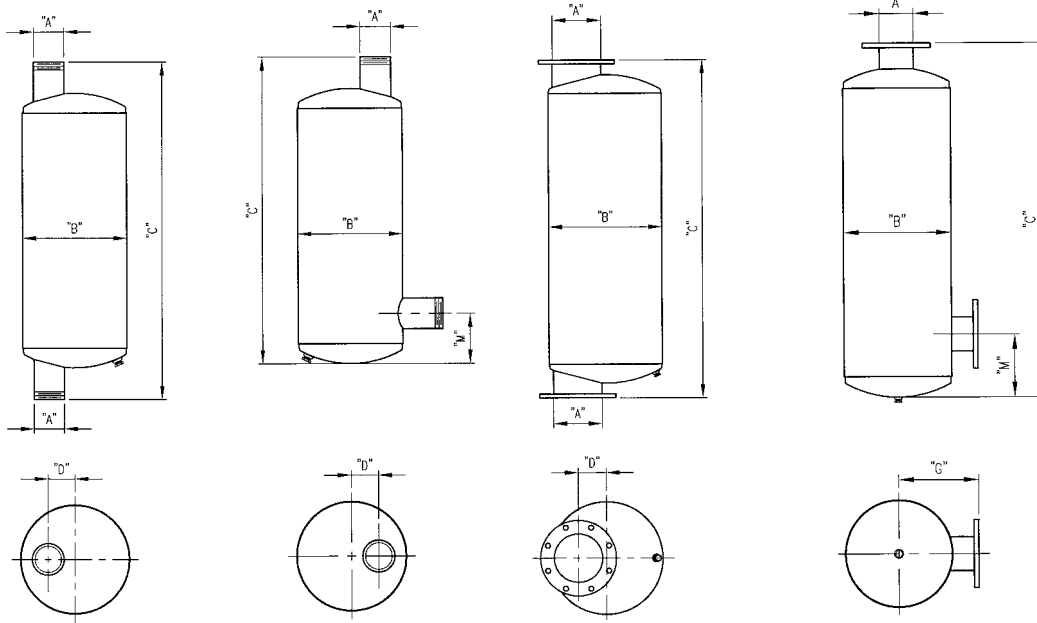

BMER
Sizes 1"
Thru 3 1/2"

BMER-L
Sizes 1"
Thru 3 1/2"

BMER
Sizes 4"
Thru 48"

BMER-L
Sizes 4"
Thru 48"

Catalog Number	Dimensions in Inches							Estimated Weight in lbs.	
	All Models		BMER	BMER-L		M			
	A	B	C	C	G	BMER-L		BMER	BMER-L
						Min.	Max.		
BMER-1	1	4 1/2	16	13	5 1/4	2 1/4	4 1/2	10	10
BMER-1.5	1 1/2	6 1/2	25	22	6 1/2	3 1/2	6 1/2	16	16
BMER-2	2	8	26	23	7	4	8	20	20
BMER-2.5	2 1/2	8	26	23	7	4	8	25	25
BMER-3	3	10	33	30	8	5	10	40	40
BMER-3.5	3 1/2	10	33	30	8	5	10	43	43
BMER-4	4	12	38	35	9	6	13	70	64
BMER-5	5	14	38	35	10	7	16	84	77
BMER-6	6	16	47	44	11	8	20	129	119
BMER-8	8	20	60	57	13	9	26	224	202
BMER-10	10	24	80	77	15	11	35	342	308
BMER-12	12	28	88	85	17	13	39	472	425
BMER-14	14	30	102	99	18	14	50	602	542
BMER-16	16	36	126	123	21	16	62	1021	939

Notes: - Flanges are drilled to match 125 lb. American Standard Flanges
 - Larger Units available upon request
 - Specifications subject to change without notice